

[72] Inventor **Harvey L. Snow**
 San Jose, Calif.
 [21] Appl. No. **766,672**
 [22] Filed **Oct. 21, 1968**
 [45] Patented **Jan. 5, 1971**
 [73] Assignee **Hydro Cycle Inc.**
 San Jose, Calif.
 a corporation of California
 Continuation-in-part of application Ser. No. 684,310, Nov. 20, 1967, now abandoned.

[56]	References Cited		
	UNITED STATES PATENTS		
2,741,207	4/1956	Leone	114/66.5
1,935,622	11/1933	Eddy	114/66.5
2,777,412	1/1957	Kiekhaefer	9/6X
2,980,924	4/1961	Canazzi	9/6
3,369,518	2/1968	Jacobson	115/70
3,373,715	3/1968	Stacey	115/70

Primary Examiner—Trygve M. Blix
 Attorney—Paul B. Fihe

[54] **WATERCRAFT AND METHOD OF FABRICATING THE SAME**
 19 Claims, 11 Drawing Figs.

[52] U.S. Cl. 115/70,
 114/66.5
 [51] Int. Cl. B63b 1/18
 [50] Field of Search. 9/6, 1;
 114/56, 66.5; 115/70

ABSTRACT: A watercraft including a hull having a central narrow elongated planing surface below its keel, shallow-angled hull surfaces projecting outwardly therefrom, and a superstructure including a pedestal seat and a handle bar at the front operably interconnected to an outboard motor at the rear thereof.

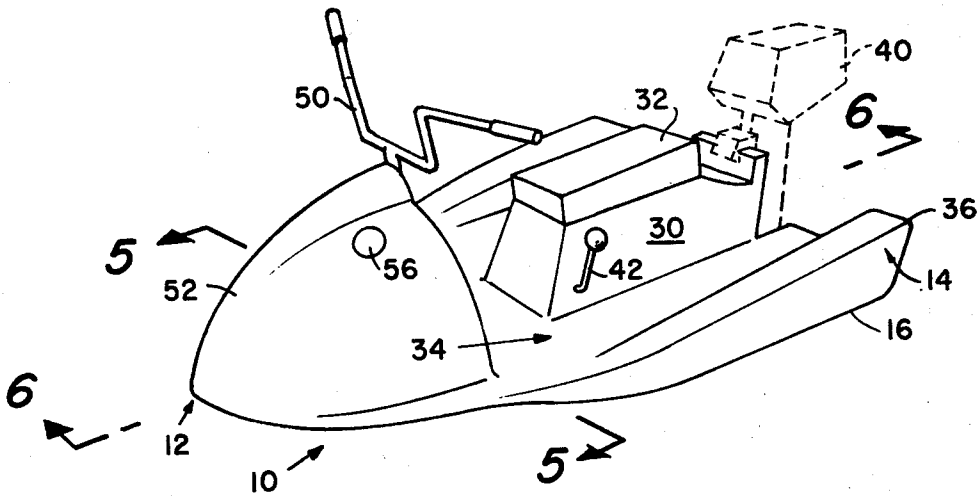

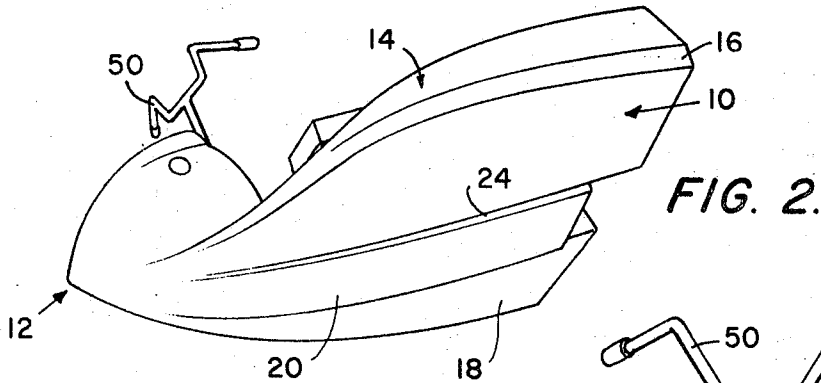

FIG. 2.

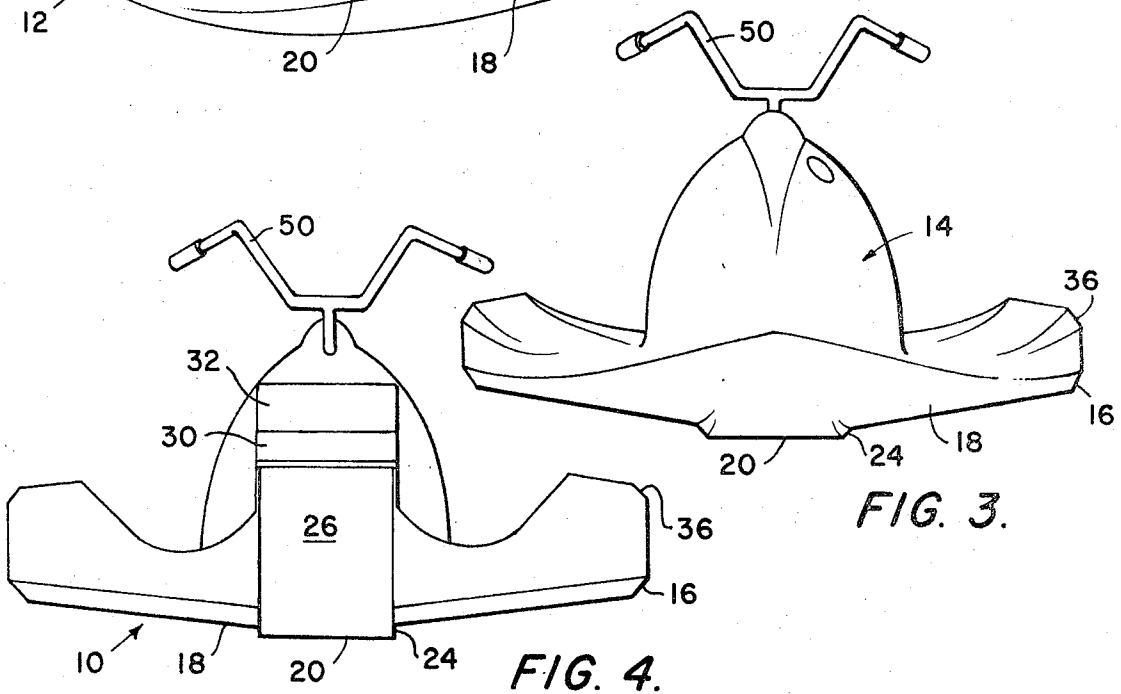

FIG. 3.

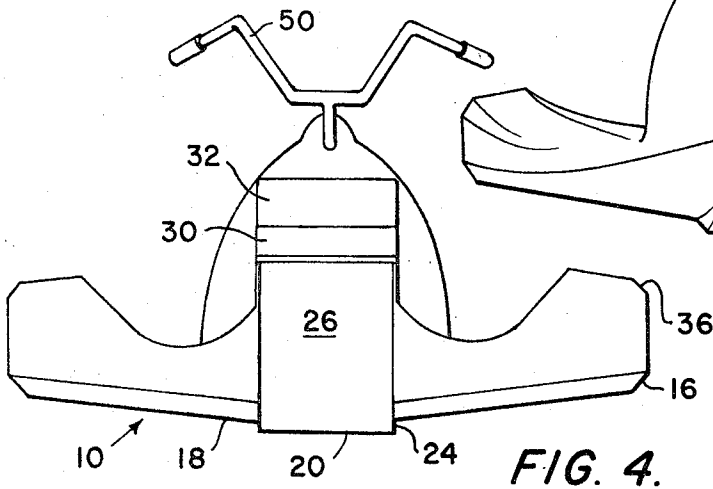

FIG. 4.

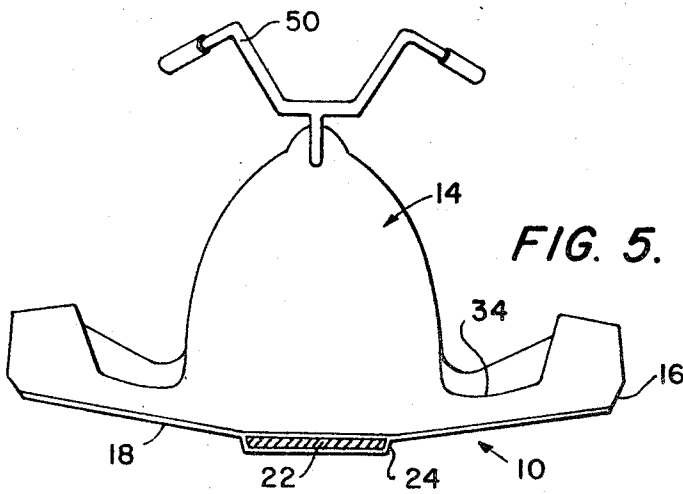

FIG. 5.

INVENTOR
HARVEY L. SNOW

BY

Paul B. Fike

PATENT AGENT

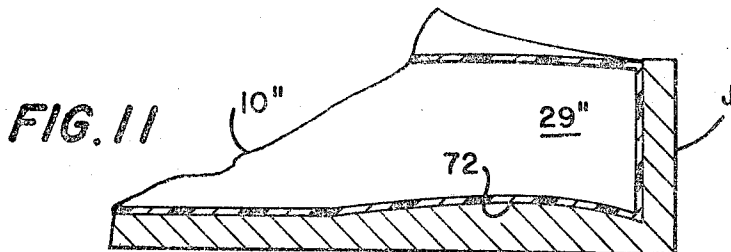
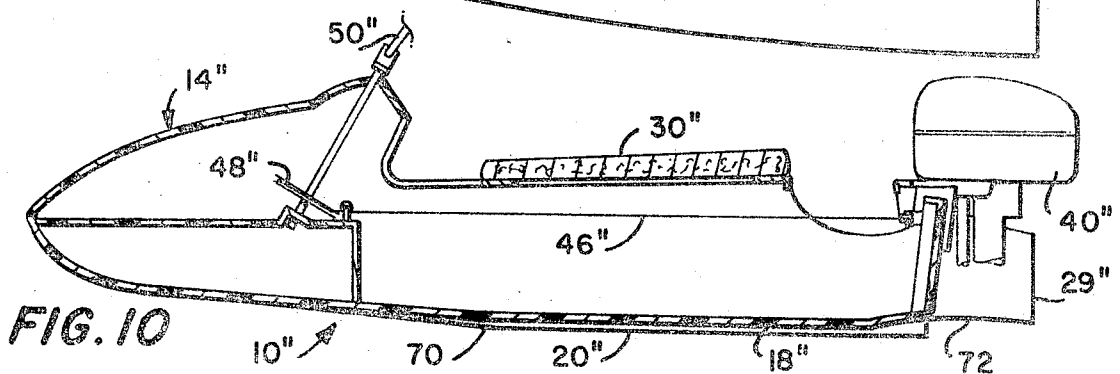
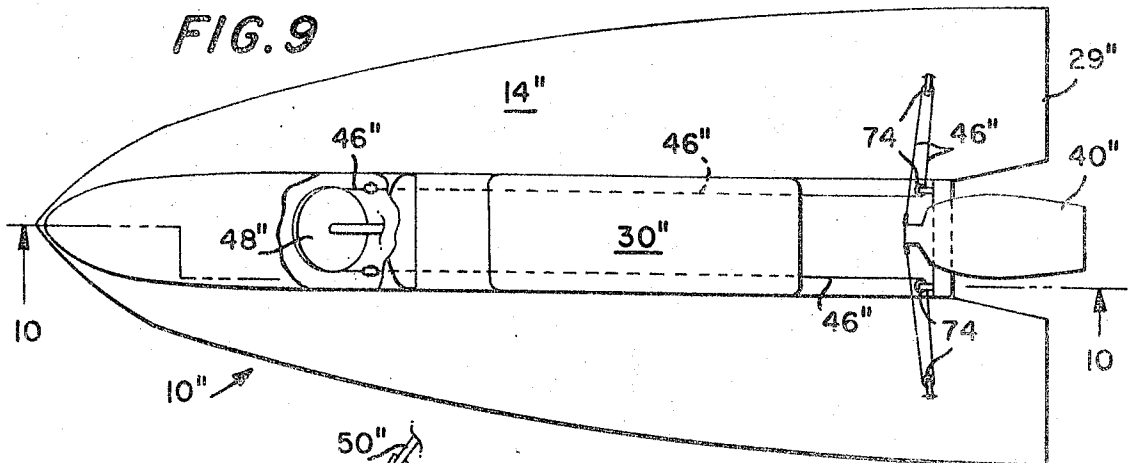
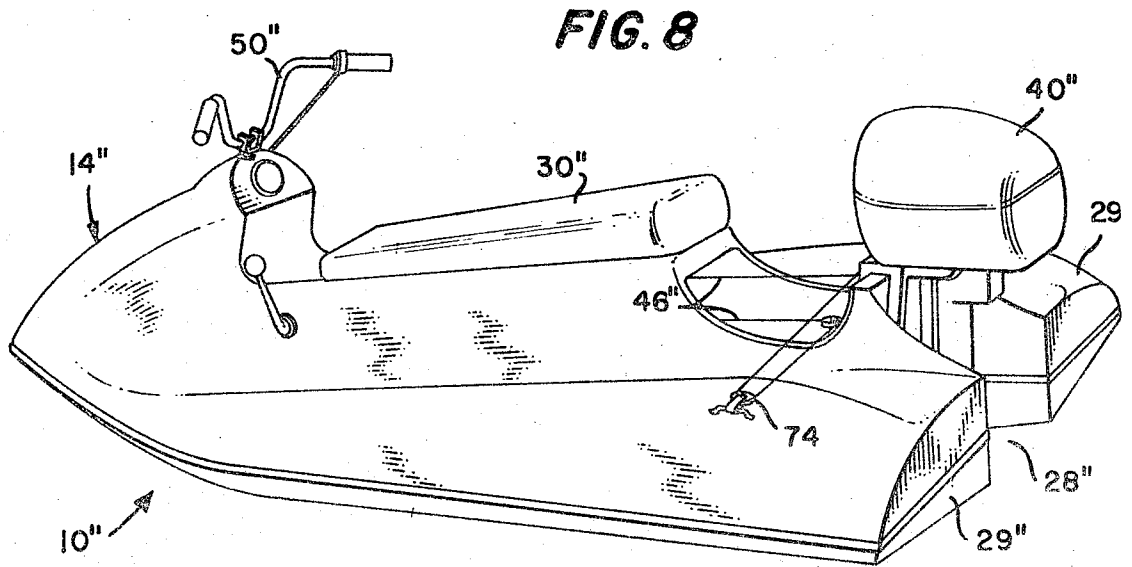

INVENTOR.
HARVEY L. SNOW

BY

Paul B. Eke

PATENT AGENT

WATERCRAFT AND METHOD OF FABRICATING THE SAME

This application is a continuation in part of application No. 684,310 filed Nov. 20, 1967 and now abandoned.

The present invention relates generally to watercraft and, more particularly, to that type of watercraft which presents a planing surface to the water so that minimal frictional resistance to motion of the watercraft is encountered, and to the method of fabricating such watercraft.

BACKGROUND OF THE INVENTION

Innumerable hull designs have been proposed to reduce the water resistance encountered during movement of a watercraft over the surface of the water through the general expedient of providing a flat planing surface which render the craft capable of skimming over the surface of the water after a certain minimal speed has been attained. For the most part, to provide stability of the watercraft, the planing surface has a rather large transverse dimension and to enable planing at a minimal speed, the planing surface also has a rather large dimension longitudinally of the watercraft. Not only do these dimensional requirements increase the overall water resistance to motion of the planing surface itself, but, most frequently, result in a design of a hull having a shallow draft which presents problems when choppy water is encountered, a common example being the flipping of the conventional hydroplane when its slightly elevated bow encounters a wave.

SUMMARY OF THE INVENTION

It is accordingly an objective of the present invention to provide a novel form of planing watercraft whose hull design is such that the planing surface has a minimal area thus to reduce water resistance to movement and yet which at the same time assures stability and maneuverability of the craft in smooth or rough water, and to also provide a novel method of fabricating such watercraft.

In general terms, the hull of the watercraft, embodying the present invention, is of rather shallow draft including an elongated but rather narrow planing surface formed along its keel, such planing surface being laterally joined by slightly upwardly inclined hull surfaces so that the overall transverse configuration of the hull is that of a shallow V. Preferably, a slight step is formed at opposite sides of the planing surface so that if planing speed has been established, this central narrow planing surface provides substantially the entire support for the moving watercraft and permits the same to be banked and turned quickly after the fashion of a motorcycle. However, lateral stability precluding excessive banking of the craft is provided by the adjacent shallow V-sections of the hull.

The forward portion of the hull preferably tapers outwardly from a bow section having a deep V-configuration which permits ease of entry into a small wave and the flare of the bow gradually fades into angularly disposed chine sections which cooperate with the bow area to maintain the forward portion of the hull above the surface of the water, whether such surface be calm or somewhat rough.

Preferably, spousons extend rearwardly from the hull stern at opposite sides thereof, forming therebetween a central cutout portion within which a conventional outboard motor is centrally received. In this manner, additional buoyancy for support of the motor is provided. However, such additional buoyant effect, at the stern, although providing support for the motor and restricting any reverse tipping of the hull during rapid acceleration, tends to lower the bow of the hull. Accordingly, to preclude bow entry into small waves and a "nosing under" effect, a slight V-shape in the longitudinal undersurface of the hull is provided. More particularly, the apex of the V is substantially centered longitudinally of the hull, and provides a raised angle on the front portion of the hull undersurface of approximately 2 degrees.

To provide additional stability, a "hook" is provided in the hull undersurface adjacent the stern, such "hook" being

defined by a longitudinal concavity in the hull undersurface extending for approximately 18 inches and having a maximum central depth of no more than 1/2 inch.

While various superstructures can be attached to the hull section, because of its motorcyclelike operating characteristics, such superstructures can conveniently take the form of a central pedestal mounted amidships to provide a seat for an occupant, and a forward pedestal which can mount a handlebar suitably connected in a novel fashion to the mentioned outboard motor mounted on a transom at the rear of the craft. The superstructure from its central position extends outwardly in a deck which slightly rises towards its outer edge so as to be considerably spaced upwardly from the hull thus to provide a hollow flotation structure serving to maintain the craft in a stable upright position even when at rest.

Both the hull and superstructure are preferably formed by individual integral sections of molded fiberglass joined at their peripheries with the outboard sections filled with buoyant plastic foam under pressure. The mentioned "hook" is formed by supporting the stern portion of the hull over a convex jig during such pressurized insertion of the plastic foam, thus to effect automatically the desired concave "hook" configuration.

BRIEF DESCRIPTION OF THE DRAWINGS

As will be more apparent hereinafter, alternate superstructures and slight modifications in the hull design can be envisioned without departing from the spirit of the invention and as a consequence several exemplary embodiments of the invention are depicted in the accompanying drawings wherein:

FIG. 1 is a perspective view of a watercraft embodying the present invention as observed from the upper front quarter thereof,

FIG. 2 is a perspective view of the undersurface of the hull of the watercraft,

FIG. 3 is a front view of the structure,

FIG. 4 is a rear view thereof,

FIG. 5 is a transverse sectional view taken substantially along line 5-5 of FIG. 1,

FIG. 6 is a longitudinal central sectional view taken along line 6-6 of FIG. 1,

FIG. 7 is a side elevational view of a modified embodiment of the invention,

FIG. 8 is a perspective view, similar to FIG. 1, of another modified embodiment of the invention,

FIG. 9 is a top plan view of the FIG. 8 structure with portions broken away to show details of its steering arrangement,

FIG. 10 is a central longitudinal sectional view taken along line 10-10 of FIG. 9, and

FIG. 11 is a fragmentary sectional view illustrating the formation of the stern hook in the bottom of the hull during fabrication thereof.

DESCRIPTION OF THE PREFERRED EMBODIMENTS

With initial general reference to FIGS. 1 and 2 the watercraft includes two basic elements, each of which are preferably formed by a single molded fiberglass structure. The underlying element which constitutes the hull 10 of the watercraft is generally of shallow substantially flat configuration tapering outwardly in horizontal outline from a point at the bow 12 of the craft to a relatively broad beam dimension throughout the remainder of its length. The overlying superstructure 14 has the same general horizontal outline so that it can be placed over the described hull structure and sealed thereto in a conventional fashion.

As best shown in FIGS. 2 and 3, the bow portion 12 of the hull, is generally V-shaped in transverse cross section, the sides of the V having a slightly convex configuration which gradually straightens, foreshortens and becomes more upright adjacent its perimeter as can be seen by reference to FIGS. 3, 5, and 4 in sequence thus to form sharply-angled chine sections 16 at the outer edge of the hull which join at their upper

edges the lower extremity of the molded superstructure 14, as mentioned hereinabove.

Interiorly of the chine sections 16 as viewed transversely in FIGS. 3, 4, and 5, the hull has bottom surfaces 18 forming a very shallow V-configuration which increase their angular relationship as the bow 12 of the hull is approached, so as to merge with the decreasing angle of the described chine sections, and thus ultimately form the relatively deep V at the bow of the hull. Throughout the majority of the length of the entire structure, these bottom hull surfaces 18 are disposed at a rather shallow angle relative to the horizontal and preferably no more than ten degrees. As these laterally-extending and slightly angled bottom surfaces 18 approach the center or keel portion of the hull, they join opposite edges of a central narrow-elongated planing surface 20 formed by the molding of the fiberglass over a keel member 22 (see FIG. 6). As clearly illustrated in FIGS. 3, 4, and 5, a slight step 24 is formed at the juncture between each of the angularly-disposed bottom hull surfaces 18 and the central planing surface 20, which conveniently can be approximately one inch in vertical dimension. The transverse dimension of such planing surface 20 is considerably greater than the step 24 and is preferably about one quarter the entire transverse dimension of the hull 10. For example, if the hull structure has an overall beam of 48 inches, the central horizontal planing surface 20 preferably has a transverse dimension of approximately 12 inches.

Preferably, the steps 24 at the opposite edges of the planing surface 20 are substantially vertical throughout most of the length of the hull, but, toward its forward portion thereof, gradually attain a divergent taper, as clearly illustrated in FIG. 3, and, in turn, the planing surface 20 gradually merges with the joining surfaces of the angularly disposed bottom surfaces 18 of the hull, as they approach the bow so that the planing surface disappears at this point and only the V-shaped bow portion 12 of the hull remains at its foremost end. Thus, while for most of the length of the craft, it includes a central substantially horizontal planing surface 20, and shallow upwardly-angled bottom surfaces 18 extending laterally from opposite sides thereof, and a final sharply angled pair of chine sections 16 adjacent its outermost edge, all of the surfaces merge towards the forward or bow end of the craft to form the single V-shaped bow section thereof. The central planing surface 20 terminates before the angular bottom surfaces 18 at the hull stern, leaving a central cutout portion 28 which will accommodate an outboard motor 40 indicated in phantom lines in FIGS. 1 and 6, the outer stern sections of the hull then taking the form of sponsons 29.

Whereas the aforementioned superstructure 14 has the same general horizontal outline as the described hull 10 so that it can be superposed thereover and joined in suitable sealing relationship thereto at its edges, it can have various configurations to accommodate the occupants of the craft, a drive mechanism therefor and a suitable steering mechanism. As shown, most clearly in FIGS. 1 and 6, the single molded fiberglass superstructure element preferably includes an upwardly projecting hollow pedestal 30 at a location amidships of the entire structure that is arranged to receive a cushion 32 to provide a seat for the occupants. On either side of this pedestal 30 the superstructure 14 falls away to form a deck surface 34 upon which the feet of the occupant or occupants can be placed. The deck 34 extends laterally in an angularly upward disposition for a predetermined distance and thence directly outwardly and finally downwardly to join the hull 10 and form what may be considered the gunwale 36 of the structure. Preferably, between this deck 34 of the superstructure 14 and the hull 10 therebelow, plastic foam (not shown) is inserted to add buoyancy to the entire structure and because of the outward inclination of the deck structure, such buoyancy is maximized towards the outer edges of the craft. As one progresses forwardly along the watercraft, the outer deck surface 34 lowers and since, as previously described, the underlying hull 10 slopes upwardly as its various sections merge into the V-shaped bow end of 12 of the craft, these buoyancy

chambers formed at the outer lateral edges of the structure terminate leaving only the rather shallow hullstructure at the bow end remaining. Because of this particular configuration of the hull 10 and the lateral sections of the superstructure greater buoyancy is obtained at the rearmost or stern end of the structure whereat an outboard motor 40 is suitably mounted on a heavy transom 26 mounted at the rear of the keel 22 within the joined peripheral sections of the molded fiberglass of the superstructure 14 and hull 10 adjacent the rear end of the structure where it is centrally cutout as indicated at 28.

Any suitable outboard motor 40 can be employed, but it has been found that a watercraft, having a beam of 4 feet and an overall length of approximately 7 feet, as described, can be driven over the water at speeds in excess of 30 miles an hour with an outboard motor having a power rating of no more than 14 horsepower.

For controlling energization of such motor 40, a pivoted lever 42 can be conveniently mounted on the side of the seat-supporting pedestal 30 and when moved forwardly from the disposition, shown in FIG. 1, will effect through an appropriate connecting cable 44 (see FIG. 6), appropriate rotation of the outboard motor propeller to effect forward motion of the entire craft. In turn, if the pivoted lever 42 is moved to the illustrated neutral position, the connecting cable 44 effects idling motion of the propeller and a further rearward movement of the control lever 42 will effect rotation of the propeller in the reverse direction to enable rearward motion of the craft in the water. Since outboard motors are conventionally designed to provide for such forward, reverse, or neutral actuation, no further details of the structure or operation of the motor 40 itself will be given.

It is also well known that outboard motors normally include pivotal mounts enabling turning thereof about a vertical axis and additional steering cables 46 are connected between the motor and a lever 48 at the lower end of a vertically-pivoted handlebar 50 mounted in a second pedestal 52 in front of that which carries the operator's seat 32. The steering cables 46 can conveniently pass through the space between the molded fiberglass superstructure 14 and the molded fiberglass hull 10 thereunder. This forward pedestal 52 upon which the handlebar 50 is mounted also is an integral part of the molded fiberglass superstructure and its hollow interior conveniently serves to house a gasoline tank 54 having a suitable fluid communication with the outboard motor 40 at the rear of the craft. Additionally, a gas cap 56 is formed in the upper portion of the pedestal 52 to facilitate replacement of the fuel.

In view of the fact that the structure, as described and shown in FIGS. 1 through 6, inclusive, is relatively simple and can be formed from molded fiberglass sections, with the dimensions as mentioned, that is an overall length of approximately 7 feet and a maximum beam dimension of 4 feet, such structure need weigh no more than 90 pounds, additional weight being added by the motor 40, whose weight obviously will depend upon its size. It will therefore be obvious that the entire structure is very portable and can conveniently be carried in most station wagons.

When the structure, as described, is at rest in the water, the existing water line will appear substantially as indicated at WL in FIG. 3, so that not only is the central planing surface 20 below the surface of the water, but the upwardly angled bottom surfaces 18 of the hull 10 also are in contact with the water throughout most of their width, a slight variance being encountered depending upon the weight of the occupant or occupants of the watercraft. As a consequence, substantially the entire length of the craft and its entire beam is in water contact to provide a stable structure when at rest.

When the motor 40 is energized to instigate forward movement of the watercraft the sloping V-shaped bow 12 will attempt to rise over the surface of the water and as continued increase in speed is attained, the angled surfaces 18 of the hull 10 are gradually brought out of contact with the water until finally when a speed in excess of 12 miles per hour is obtained,

substantially only the narrow elongated planing surface 20 will be in contact with the water and, as a consequence, relatively high rates of speed can be obtained with motive power of relatively low horsepower. As previously mentioned, a 14 horsepower motor can drive a 7 foot craft, as described, at a speed in excess of 30 miles an hour with an occupant weighing 180 pounds riding on its seat. Depending upon the precise speed and the weight of the occupant and the motor 40, the total vertical penetration of the craft into the water will obviously vary, but, under normal operating conditions, with a 14 horsepower motor and an occupant weighing approximately 180 pounds only the central planing surface 20 and the steps 24 at opposite sides thereof will be in substantially continuous engagement with the supporting water. The horizontal planing surface 20 maintains the structure on the surface and the contact between the water and the steps 24 at the side of such planing surface 20 maintain the entire structure in a balanced, upright position, even though substantially no water contact exists with the laterally extending angular surfaces 18 of the hull. Because of this minimal contact, relatively great speeds, as mentioned, can be obtained with a relatively small outboard motor.

However, in spite of the relatively small contact and in fact because of such relatively small contact between the central planing surface 20 of the hull 10 and the water thereunder, turning of the craft in the water is facilitated. If the handlebar 50 is turned to effect a rotation of the outboard motor 40 in one direction, it will be apparent that the rear portion of the craft will be urged initially in the opposite direction and because of the small contact with the underlying water, such turning will be rapid and the craft becomes extremely maneuverable, being capable of complete turning in a distance no more than twice its overall length. Furthermore because of the configuration of the hull 10 the entire watercraft will bank or slope downwardly in the direction of turning to facilitate such maneuverability, as described. Particularly, as the motor 40 urges the stern end opposite to the direction of turning, a buildup of water is achieved by the lateral shifting of the step 24 adjacent the stern which, in turn, positively effects the desired banking of the craft. Finally, if the turning be excessive, one angular side surface 18 of the hull bottom will come into contact with the water so as to prevent excessive banking and ultimate capsizing.

Even though the structure, as described, is extremely maneuverable and is capable of moving over the water at a relatively high rate of speed, if choppy water is encountered, no deleterious effects result. More particularly, if a small wave is encountered by the bow 12 of the craft, it immediately lifts because of its V-shaped configuration and no tripping of the craft is experienced. Furthermore, because of the slow angular deviation of the chine sections 16 at the side of the craft, entry into waves even at a slight angle will still effect a lighting of the hull 10 rather than a tripping penetration into such wave. As a consequence, the craft is capable of operating with the described speed and maneuverability over substantially all waves encountered in normal use on a river or a lake and furthermore can usually handle very well the long swells encountered in the ocean.

It will be apparent that substantial changes can be made in the hull design, that of the superstructure, or the manner of propelling the watercraft without departing from the spirit of the invention and one slight modification designed for use by fishermen is illustrated in FIG. 7. In such modification, the major portion of the structure is identical to that shown and described in connection with the first embodiment of the invention and corresponding parts will accordingly be indicated by like reference numerals with an added prime notation to enable differentiation.

The underlying hull structure 10' is identical and the superstructure 14' is generally similar in that it includes a pedestal 30' amidships and one adjacent the bow 12' of the watercraft. However, the forward pedestal 52' has no handlebar but merely houses a gasoline tank interiorly thereof, as

in the first embodiment, and preferably includes a flat tablelike cover 60, which is relatively rigid and hard so that a fisherman can perform various operations such as baiting of a hook thereon. This cover 60 can, of course, be lifted to expose, in addition to the aforementioned gasoline tank, a storage compartment within which a bait box or the like can be carried. The rearward pedestal 30' mounts a swivel chair 62 on which the fisherman may be seated. To free his hands for the fishing operation such chair 62 is preferably connected by a pivoted linkage 64 to the motor 40' so that as the seat is turned by the fisherman, a corresponding turning of the motor for purposes of steering is achieved. Thus, for example, when travelling, the fisherman can continue to hold the fishing pole with both hands and maneuver the watercraft by the simple turning of the chair 62. Since other details of the construction of this modified embodiment correspond to those described in connection with the first embodiment of the invention, as does its general operation, no further delineation of those details will be repeated.

Yet another significant modification of the invention is illustrated in FIGS. 8-11 which generally constitutes a watercraft of slightly larger dimensions than that shown and described as the first embodiment of the invention so that several persons can be carried during operation more conveniently. Generally, the hull 10'' and superstructure 14'' have a similar configuration and accordingly corresponding parts will be indicated by like reference numerals with an added double prime notation to enable differentiation.

More particularly, since this modified watercraft is slightly larger, a more powerful outboard motor 40'' is preferably employed and since such larger motor has greater weight, certain significant modifications in the hull design are incorporated although it will be apparent that these modifications can as well be incorporated in the first embodiment of the invention, if desired.

Specifically, because of the greater weight of the motor, the sponsons 29'' at the opposite sides of the stern project further rearwardly, thus to provide a larger cutout section 28'' for the larger motor and at the same time provide additional buoyancy to preclude reverse tipping of the watercraft during initial acceleration. At certain speeds however, this additional buoyancy at the stern of the watercraft tends to force the bow portion of the watercraft downwardly so that if small waves are encountered, the tendency might exist for the bow to "nose-under" and thus effect a tripping which might cause a dangerous forward flipping of the watercraft. Accordingly, the undersurface of the hull including the central planing surface 20'' and the adjacent sloping surfaces 18'' are provided with a shallow longitudinal V-shaped configuration. The center of the V indicated at 70, is at or slightly forward of the longitudinal center of the hull 10'' and as best shown in FIG. 10, provides for a raising of the forward portion of the planing surface through an angle of approximately 2°. In this manner the additional buoyancy of the stern of the watercraft is accommodated without any deleterious tripping of the bow portion.

To provide additional stability, a slight hook 72 is formed in the undersurface of the hull 10'' adjacent its stern. More particularly, this hook 72 takes the form of a longitudinal concavity preferably extending for about 18 inches adjacent the hull stern, the maximum longitudinally-centered depth of the concavity being preferably between ¼ and ½ inch, as best indicated in FIG. 10. As a result of such hook and the previously described longitudinal V in the hull shape, this modified watercraft operates with greater stability under all water and speed conditions.

As previously mentioned the superstructure 14'' of this modified embodiment is generally similar to that described in connection with the first embodiment of the invention with the central pedestal 30'' being somewhat lengthened to accommodate several persons.

In addition, as best shown in FIG. 9, a slightly modified steering arrangement is provided which facilitates operation of the watercraft. In the first place, the steering post with a

handlebar 50'' attached to its upper end is sloped at a considerable angle forwardly and downwardly so that as the handlebar is turned to steer the watercraft, no interference with the driver is experienced. The lower end of the steering post carries lever means in the form of a pulley 48'' about which a cable 46'' is trained to pass rearwardly through the central pedestal adjacent opposite sides thereof. The two cable sections then pass around small pulleys 74, thence angularly outwardly and around additional pulleys mounted on the outboard sponsons 29'', and finally inwardly to form substantially straight line lateral connections at their ends to the pivoted outboard motor 40'', thus to provide most efficient leverage for turning of such motor. Whether the motor 40'', be turned to either the left or the right, a direct lateral pull in a direction tangential relative to the rotative axis of the motor is provided.

This modified watercraft is formed in substantially the same manner as that described in connection with the first and second embodiments of the invention, with the hull 10'' being a single integral molded fiberglass section which is subsequently joined at its periphery to the single-piece molded fiberglass superstructure 14''.

The hull 10'' and superstructure 14'' joined at their peripheries thus form a thin flexible shell of fiberglass reinforced plastic in the general shape of the watercraft. For forming to close tolerances the specific irregular curves, such as the hook 72 on the stern of the hull, expanding plastic foam is injected into the interior of the shell under atmospheric conditions. The expanding foam exerts pressure on the interior of the flexible shell and forces it against exterior molding surfaces to achieve the ultimate hull configuration. More particularly as shown in FIG. 11, the hull 10'' which is initially substantially flat in the region of the hook is confined against a jig J having a slightly convex configuration. Plastic foam, such as an expandible rigid polyurethane foam, is injected into the hollow interior of the shell and the expanding foam deforms the shell against the convex jig to form the hull into the disclosed concave hooked configuration. This hooked configuration is maintained by curing or setting of the plastic into rigid foam within the shell interior, namely within the sponsons 29'' of the hull of FIG. 11.

It will be obvious that yet further modification can be envisioned without departing from the spirit of the invention and the foregoing description of three embodiments is to be considered as purely exemplary and not in a limiting sense.

I claim:

1. A watercraft which comprises:
 - a hull including a narrow elongated flat planing surface formed along its keel with substantially parallel edges and a transverse dimension greater than one-fifth but less than one-half of the transverse hull dimension;
 - substantially planar hull surfaces extending laterally upwardly from opposite sides of said planing surface at shallow angles; and
 - means forming a step up from each edge of said planing surface to the adjacent edge of said shallow-angled hull surfaces, each step being dimensionally much smaller than the width of said elongated planing surface.
2. A watercraft according to claim 1 which comprises, chine sections angled upwardly at steep angles from the outer edges of said shallow-angled hull surfaces.
3. A watercraft according to claim 2 wherein, said central planing surface, said shallow-angled hull surfaces, and the adjacent surfaces of said chine sections gradually merge in a single V-shaped surface at the bow portion of the hull.
4. A watercraft according to claim 3 wherein, said V-shaped bow surface slightly rises toward the foremost extremity thereof.
5. A watercraft according to claim 4 wherein, said hull has a horizontal outline which tapers outwardly from a point at its bow end thereafter has a beam dimension considerably in excess of its draft dimension.
6. A watercraft according to claim 1 which comprises:
 - a flat elongated keel; and

said hull being formed by a single molded element of fiberglass with the portion over said keel forming said planing surface.

7. A watercraft according to claim 1 which comprises, a superstructure joined to said hull along its perimeter and including a central pedestal adapted to provide a seat for an occupant.

8. A watercraft according to claim 7 which comprises:

- a swivel chair on said pedestal; and
- means adapted to connect said chair to a steering unit for the watercraft.

9. A watercraft according to claim 1 wherein, the undersurface of said hull has a shallow longitudinal V-shape.

10. A watercraft according to claim 9 wherein, the apex of said V is substantially centered longitudinally of said hull undersurface.

11. A watercraft according to claim 1 wherein, said lateral hull surfaces extend rearwardly further than said central planing surface thereby to form sponsons adjacent the stern portion of the watercraft.

12. A watercraft according to claim 11 which comprises, means adapted to mount a motor between said sponsons.

13. A watercraft according to claim 12 which comprises:

- a superstructure joined to said hull and carrying said motor-mounting means; and
- steering means mounted on said superstructure and including cables adapted for connection to the motor and extending laterally outboard from their connection to said motor.

14. A watercraft according to claim 13 wherein, said steering means includes a steering post mounted on said superstructure to extend forwardly and downwardly adjacent the bow portion thereof.

15. A watercraft according to claim 1 wherein, the undersurface of said hull includes a concave hook adjacent the stern portion thereof.

16. A watercraft according to claim 1 which further comprises, sponsons substantially outboard of said narrow planing surface to provide stabilizing flotation to said hull on the lower side of said hull during a turn.

17. A hull configuration for effecting safe controlled turns of a shallow draft substantially flat-bottom planing watercraft comprising:

a narrow elongated planing surface formed along the keel of said hull with substantially parallel edges and a transverse dimension greater than one-fifth but less than one-half of the transverse hull dimension;

hull surfaces extending laterally upwardly from opposite sides of said planing surface at shallow angles;

means forming a step up from each of the opposite edges of said planing surface to the adjacent shallow angled hull surface which is substantially smaller than the width of said planing surface to pile up water on the side of said hull opposite a turn; and

sponsons on said hull substantially outboard from said planing surface to provide flotation for that side of the hull upon which water is not piled up by the step during said turn.

18. A watercraft comprising:

- a hull having a planing surface formed along its keel having parallel edges with a transverse dimension more than one-fifth and less than one-half of the transverse hull dimension, lateral surfaces joined to said planar surface by shallow steps on both sides and extending laterally upwardly at shallow angles and transom means for mounting an outboard motor at its stern;

a pedestal carrying a driver's seat mounted on said hull;

- an outboard motor secured to said transom means;
- means for steering the watercraft including a pivoted handlebar forward of said driver's seat, lever means at the lower end of said handlebar within said hull; and
- a flexible steering cable attached at its midlength to said lever means and at its ends to said motor, all of said steer-

ing cable except its ends being enclosed within said hull and pedestal.

19. The watercraft of claim 18 wherein, the ends of said steering cable first extend laterally outboard from their points

of connection to said motor and then from the outboardmost point of each cable portion into the interior of said pedestal and hull to said lever means.

10

15

20

25

30

35

40

45

50

55

60

65

70

75